

Sprint  **Scan 35**

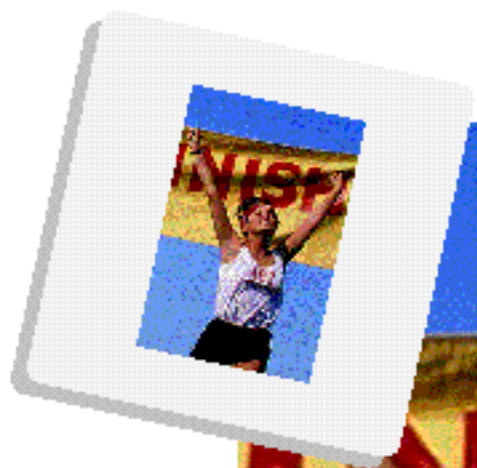

Polaroid

Table of contents

Quick Scanning Guide	iii
----------------------	-----

1 Introduction

Macintosh system requirements	1-2
PC system requirements	1-3
Technical Support	1-4
Registration card	1-4
Unpacking	1-5

2 Setup and use

The scanner	2-1
Positioning the scanner	2-3
SCSI guidelines	2-4
SCSI ID numbers	2-6
Installing a SCSI adapter in a PC	2-7
Connecting the scanner to your computer	2-7
Diagrams of various SCSI configurations	2-8
Turning on the scanner	2-10
Inserting originals for scanning	2-11

3 Care and maintenance

Maintenance	3-1
Changing the lamp	3-2
Changing the fuse (ES scanner only)	3-4
Troubleshooting	3-6
SprintScan 35 warranty	3-8
SprintScan 35 service	3-8
Polaroid Offices and Service Centers	3-9
Radio and television interference (LE and Plus)	3-11
Radio and television interference (ES)	3-12

Appendix A: Specifications	A-1
----------------------------	-----

Index	I-1
-------	-----

Quick Scanning Guide

Use this as a quick reference for scanning. For details, see the pages indicated.

See page:

- | | |
|------|--|
| 1-5 | 1 Unpack the SprintScan 35 scanner package. |
| 2-7 | 2 Install a SCSI host adapter card in your computer (PC-compatibles only). |
| 2-6 | 3 Change the SCSI ID number of the scanner, if necessary. The scanners are factory set to SCSI ID number 6. |
| 2-7 | 4 With all equipment turned off, connect the scanner to your computer using the SCSI cable provided. If the scanner is the last device in the chain, use a terminator at the scanner (LE and ES scanners) or move the termination switch to ON (Plus scanner). |
| 2-10 | 5 Plug the power cable into the scanner and into a grounded power outlet. |
| 2-10 | 6 Turn on the scanner, then your computer. |
| -- | 7 Install the software according to the software manual. |
| 2-11 | 8 To scan an image, insert an original into the scanner. |
| -- | 9 Initiate the scan from the software (see the software manual). |

Warning: Please follow the detailed instructions in chapter 2, Setup and use for connecting the equipment. Improper connection could damage your computer, the scanner, or both.

1 Introduction

The Polaroid SprintScan 35 LE, ES, and Plus slide scanners allow you to capture and convert film images into electronic files that you can edit and incorporate into your documents and presentations. The scanners can be connected to a Macintosh computer, or an IBM-compatible computer with a SCSI host adapter installed (see page 2-7). The models are similar in function and differ as indicated.

For Macintosh users, the SprintScan 35 scanners are shipped with a software plug-in that allows you to acquire images in any Adobe PhotoShop plug-in compliant application, then edit and print them from within the application. For Windows users, the SprintScan 35 scanners are shipped with Polaroid SprintScan TWAIN driver software and are compatible with both Windows 95 and Windows 3.1 operating systems.

All three models can accommodate 35mm mounted transparencies and filmstrips. The SprintScan ES and Plus scanners can also accommodate SuperSlides (36x36mm). The units can operate at voltages from 100V to 240V.

The SprintScan 35 LE and ES scanners capture images at 10 bits per color; the Plus captures images at 12 bits per color. The scanners convert the image data into 8 bits per color (256 levels per color).

Macintosh system requirements

Minimum

- A Macintosh II family, Quadra family, PowerPC or Powerbook computer (use appropriate Powerbook SCSI cable as required)
- System 7.01 or later
- 12 MB of RAM
- A 256 (8-bit) color monitor

Recommended

- A PowerPC computer
- System 7.5
- 32 MB of RAM
- A 24-bit color monitor

SprintScan plug-in

The SprintScan plug-in requires:

- 2 MB free hard disk space
- 4 MB from the application memory

Note: Application memory is the amount of memory available for the application after the system has started. The imaging application should have enough memory (combined RAM and hard disk memory) to allow for about three times the maximum image size you plan on scanning. This means you should have the minimum memory plus enough memory for the maximum scan size. Note that the maximum scan size depends on the images and resolutions you want to scan. For example, scanning a 35mm slide at 500 dpi resolution requires about 1.2 MB of memory. Scanning the same slide at 1950 dpi requires 18 MB of memory, and at 2700 dpi, about 32 MB of memory, which means utilizing the swap area on the hard disk.

If you do not have the minimum required configuration for using the SprintScan 35, contact the dealer from whom you purchased your computer system.

PC system requirements

Minimum

- An IBM PC or compatible with 386SX, 486 or Intel Pentium microprocessor
- DOS 5.0 or later
- Microsoft Windows 3.1 or Windows 95 operating system
- 12 MB of RAM
- A 256 (8-bit) color video adapter*
- An ASPI-compliant SCSI-2 interface board

Recommended

- An IBM PC or compatible with an Intel Pentium microprocessor
- Microsoft Windows 95 operating system
- 32 MB of RAM
- High color (16-bit) or better video adapter at 1024 x 768 screen resolution

If you do not have the minimum required configuration for using the SprintScan 35, contact the dealer from whom you purchased your computer system.

*Note: Adobe Photoshop 3.0x and above requires at least a 256 (8-bit) color video adapter in order to operate.

Technical Support

Before you call, have ready the following information:

- The model of your computer, including the kind of processor, and the amount of RAM you have
- The model and serial number of your SprintScan 35
- A list of other devices attached to your system, such as CD-ROM drives, printers, external hard disks, and other SCSI devices
- A list of any other cards and drivers that you are using, including video card and driver
- Other applications you are using
- A description of the problem and the wording of any error messages on your screen when the problem occurs

Run a system diagnostic

We recommend that you run a system diagnostic utility to provide detailed information about your system before you call.

Call us

You may call Polaroid toll-free from within the U.S.A. at 1-800-432-5355, or fax the information about your problem to 1-617-386-9688, Monday through Friday, 8 A.M. to 8 P.M. Eastern Time. We offer a variety of Customer Support Services; call us for details and applicable fees. You may also write to Electronic Imaging Technical Support, Polaroid Corporation, 565 Technology Square 3B, Cambridge, MA 02139. In Canada, call toll-free at 1-800-268-6970. Outside North America, contact the Polaroid office nearest you (see pages 3-9-3-10).

Internet support

Technical Support is also available over the Internet. Connect to our web site at: <http://www.polaroid.com>

Registration card

Be sure to fill out and mail your registration card. As a registered owner, you'll receive information about software updates and about the availability of new scanning products from Polaroid.

Unpacking

The SprintScan 35 is a precision instrument. Handle it as carefully as you do your hard drive and computer. Save the protective packing materials and carton in case you need to move or ship the scanner.

The following figure shows the components you should find in the packing boxes, in addition to this manual. If you are missing anything, contact your dealer immediately.

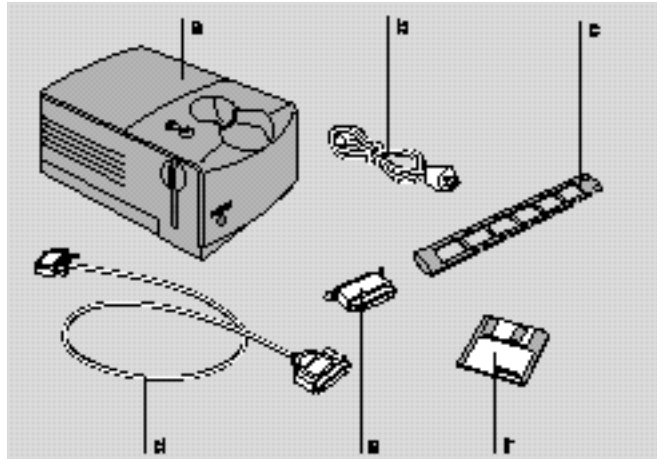

- a SprintScan 35 Slide Scanner
- b Power cord
- c A filmstrip carrier for a negative strip or unmounted slide film
- d SCSI cable with 25-pin and 50-pin connector ends
- e A SCSI terminator (not required for the Plus, which is internally terminated)
- f Polaroid software
- g Polaroid manuals (not shown)
- h Product registration card (not shown)
- i Spare lamp inside front cover (not shown)

2 Set up and use

The scanner

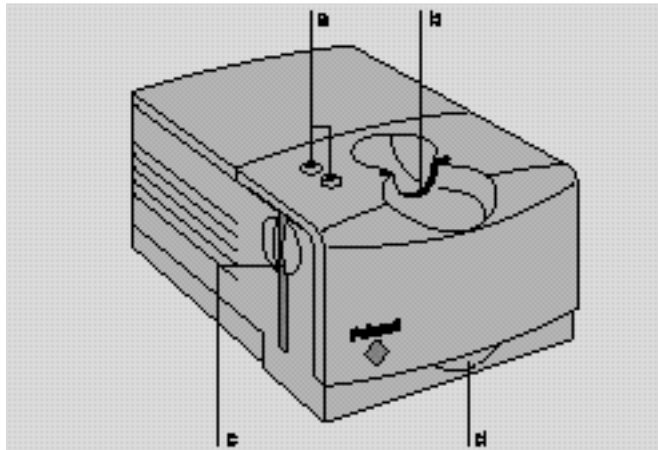

- a Power indicator light (green) and ready light (yellow)
- b Top access slot for mounted slides
- c Side access slot for filmstrip carrier
- d Release button for front cover (to change the lamp)

SprintScan 35 ES

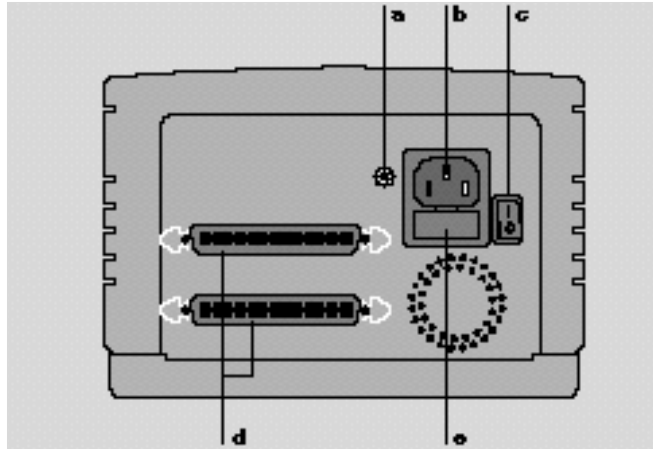

- a SCSI ID indicator
- b Socket for power cord
- c Power switch
- d SCSI connectors (two 50-pin)
- e External fuse receptacle

SprintScan 35 LE

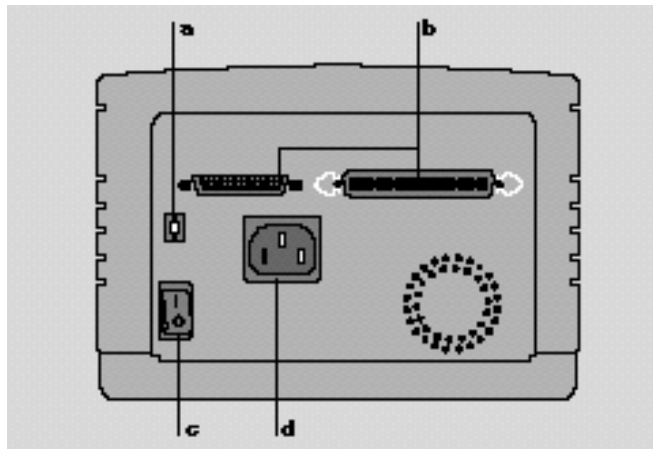

- a SCSI ID switch
- b SCSI connectors (25-pin and 50-pin)
- c Power switch
- d Socket for power cord

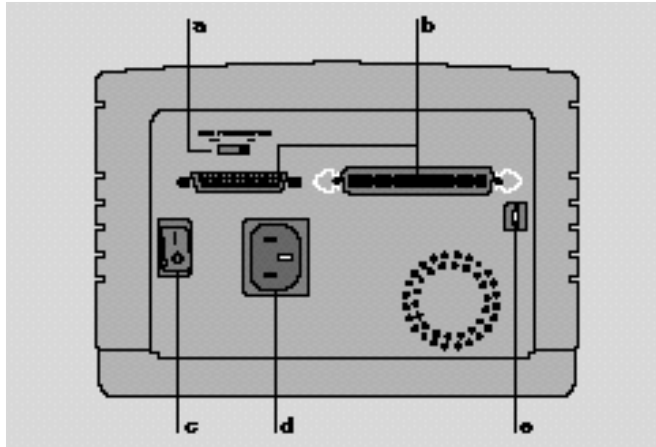

- a SCSI termination switch
- b SCSI connectors (25-pin and 50-pin)
- c Power switch
- d Socket for power cord
- e SCSI ID switch

Positioning the scanner

You must plug cables into the back of the scanner and the computer while setting up, so make sure the back is accessible for now, and adjust the scanner's position for convenience and safety later.

- The scanner should be placed near your computer on a stable, flat surface.
- When operating the scanner, you'll need to have easy access to the top and sides of the scanner for loading originals.
- Be sure to leave at least 2 inches (50 mm) of space around all sides and the top of the scanner for adequate ventilation.
- Leave clearance on the sides at the front of the scanner so that you can slide the filmstrip carrier through the side access slot.
- Vibrations or bumping during use can cause picture defects. Position the scanner for the least possibility of disturbance.

Warning: Except for the lamp (and one fuse on the ES), nothing inside the scanner is user serviceable. Do not attempt to disassemble the scanner. To do so could result in severe electrical shock and damage to the scanner. This action may also void your warranty. Contact Polaroid Technical Support if the scanner is malfunctioning. (See Technical Support on page 1-4, and chapter 3, Care and maintenance).

SCSI guidelines

About SCSI chains

The SCSI system uses special cables and termination to achieve communication between the computer and peripheral devices. To function properly, the combined length of the entire cable system must not exceed 19 1/2 feet (6 meters) and must include the appropriate number of terminators. Termination maintains the clarity of the SCSI signal along the chain of devices. A SCSI chain must always be terminated at both ends. Incorrect termination can permanently damage the computer, scanner, or any other device along the SCSI chain. Refer to the following guidelines and diagrams for more information.

Termination

The SCSI chain must be terminated at both ends of the chain. The beginning of the chain is typically the computer. In a PC, make sure the SCSI host adapter is terminated; see instructions for the SCSI adapter. (However, if you have an internal SCSI hard drive and only one SCSI adapter, then the hard drive should be terminated and not the adapter.) Most Macintosh computers include a hard disk which is internally terminated. If your Macintosh computer does not include an internally-terminated hard disk, you must place an external terminator on the first device after the computer, between the device and the SCSI cable to the computer.

Intermediate devices in the chain should not be terminated. If you have an internally-terminated device, place it at the end of the chain. (Check the manual for the device to determine if it is internally terminated or not.) If none of your devices are internally terminated, place an external terminator on the last device.

The SprintScan 35 LE and ES scanners are unterminated. If one of these scanners is the last device in the chain, add a terminator. The SprintScan 35 Plus has a termination switch to enable (turn on) or disable (turn off) the internal termination. The unit is shipped with termination off. See the illustrations on pages 2-8-2-9 for examples of various SCSI configurations.

Powerbook note: According to Apple Computer, even though this computer has an internal hard disk, you should treat it as an unterminated device. Refer to the documentation included with your Powerbook.

Connection tips

WARNING: ALL CONNECTIONS MUST BE MADE WITH THE SCANNER, THE COMPUTER, AND ALL SCSI DEVICES TURNED OFF.

- Always make SCSI connections firmly, connecting the clips or tightening the screws that secure cables and terminators. Most problems with SCSI devices are connection problems along the SCSI chain.
- The SprintScan 35 ES scanner has two 50-pin SCSI connectors and the LE and Plus scanners have two SCSI connectors – one 50 pin and one 25. A SCSI cable can be connected to either port without affecting the performance of your equipment.
- Each device on a SCSI chain must have a unique SCSI ID number. These numbers are described in the following section.
- If a 50-to-50 pin cable is required, be sure to use a cable which meets the SCSI-2 specification, such as an Apple cable.

SCSI ID numbers

WARNING: TO PREVENT DAMAGE TO YOUR HARDWARE AND SOFTWARE, READ THIS SECTION BEFORE TURNING ON YOUR SYSTEM.

Each device on a SCSI chain must have a unique SCSI ID number from 1 to 6. (Number 7 is reserved for the computer or the SCSI adapter, and 0 for the internal hard disk.) The SprintScan 35 scanners are set at the factory to SCSI ID number 6. If this number conflicts with your hard drive or any other device on your SCSI chain, you must change either the SCSI ID number of the scanner or the SCSI ID number of the other device.

Changing the SCSI ID of the scanner

- 1 Turn off the scanner.
- 2 Locate the SCSI ID selector on the back of the scanner (see below). On the LE or Plus model, press the button marked (-) or (+) above and below the switch to change the number to an ID number that is unique from other numbers in the chain, from 1 to 6. On the ES model, insert a small screwdriver into the slot and rotate the wheel until the arrow points to the number you want. See below.
- 3 The new number will take effect the next time the scanner is turned on.

WARNING: IF TWO DEVICES ON A SCSI CHAIN HAVE THE SAME SCSI ID NUMBER, NEITHER WILL WORK CORRECTLY, AND DATA MAY BE DAMAGED WHEN YOU TURN ON THE DEVICES.

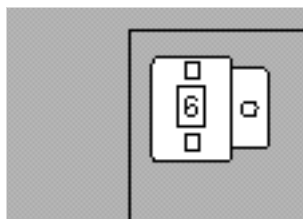

The SprintScan 35 LE and Plus scanners



The SprintScan 35 ES scanner

Installing a SCSI adapter in a PC

If you are using a PC-compatible computer, you must have a SCSI host adapter installed in your computer for connection to the scanner. We recommend an Adaptec SCSI host adapter. Before connection, be sure the settings are correct; check the documentation for your adapter. The SprintScan 35 scanner is compatible with most Windows ASPI-supported adapters (such as Adaptec).

For detailed information about installing the card, refer to the instructions provided with your adapter card.

Connecting the scanner to your computer

WARNING: ALL CONNECTIONS MUST BE MADE WITH THE SCANNER, THE COMPUTER, AND ALL OTHER CONNECTED EQUIPMENT TURNED OFF. PAY STRICT ATTENTION TO THE SEQUENCE OF INSTRUCTIONS IN THIS SECTION. FAILURE TO COMPLY MAY RESULT IN DAMAGE TO YOUR COMPUTER AND/OR THE SCANNER. SUCH DAMAGE IS NOT COVERED BY THE WARRANTY.

- 1 Turn off your computer, and then turn off the scanner.
- 2 Connect the 25-pin end of the data cable to the SCSI port on the back of your computer and the 50-pin end to the 50-pin port on the back of the scanner.

Warning: Use only the cable supplied with the scanner.

The second port can be used to connect another SCSI device to the chain, using another SCSI cable.

- 3 Terminate the signal at the last device in the chain. If the ES or LE scanner is the last device, connect the terminator provided to the 50-pin port. Then connect the SCSI cable to the terminator. If the Plus is the last device, turn termination on using the switch. Be certain to use only SCSI-specified cables for all other connections in the chain.

The diagrams on the following pages will serve as a reference to correct SCSI connections for various system configurations.

- 4 Change the SCSI address of the scanner if necessary (see page 2-6).

Diagrams of various SCSI configurations

The following diagrams illustrate different configurations. Find the appropriate configuration for your hardware, and follow the connection diagram and instructions.

Note: The shorter the SCSI chain, the better it will work. Use SCSI cables that are only as long as necessary. The chain may not exceed 19 1/2 ft. (6m) total.

Scanner is the only SCSI device

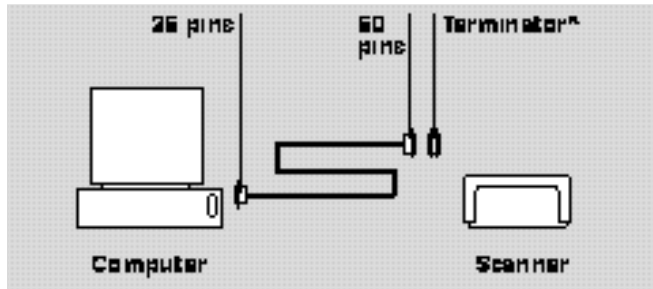

The hard disk of the computer is internally terminated. Therefore, you need to add the terminator to an ES or LE scanner. Place the terminator between the SCSI cable and the scanner. Use the SCSI cable provided.

*For the Plus model, turn the termination switch on and disregard the terminator.

Scanner and another SCSI device which is internally terminated

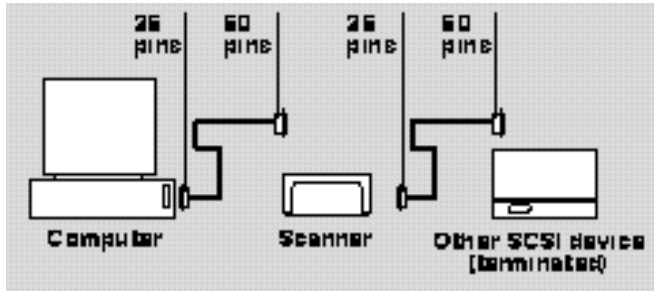

Place the terminated device at the end of the chain and do not add any additional terminators. For the Plus model, be sure the termination switch is off. Use only approved SCSI cables.

Scanner and another unterminated device

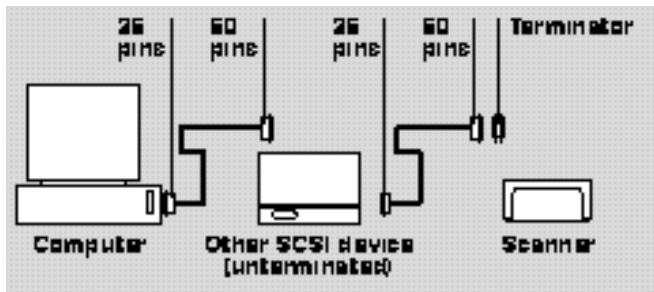

Place the scanner at the end of the chain and terminate it with the external terminator (LE and ES) or the termination switch (Plus). Do not add any additional terminators. If one external device has an internal terminator, see the previous example. Use only approved SCSI cables.

Turning on the scanner

- 1 With the scanner off, plug the power cord provided into the scanner, and then into an appropriate grounded outlet. The scanner can operate over a voltage range from 100 to 240 VAC.
- 2 Turn on the scanner; the switch is next to the power connector. The POWER indicator light on the top of the unit will light. The scanner will perform a self-test that lasts for a few seconds. If no problems are detected, the READY light will stay lit.
- 3 Once the ready light is lit, turn on your computer.

Inserting originals for scanning

The scanner can accept mounted 35mm slide transparencies. You can also scan unmounted slides and 35mm filmstrips using the filmstrip carrier included in the accessory kit.

Slides

To insert a mounted slide,

- 1 Hold the slide so that the emulsion side is facing away from you, toward the back of the scanner, and so the image is right side up for the LE scanner and upside-down for the Plus and ES scanners (see below).

The emulsion side is the side that would face toward the screen if you were using a projector. In many cases it has a duller, more matte-like finish than the non-emulsion or base side. Also, if there is any text in the image, it will be readable when the emulsion side is away from you.

- 2 Place the slide into the access slot on top of the scanner, as shown in the following figures. Make sure the slide is firmly seated in the mechanism.

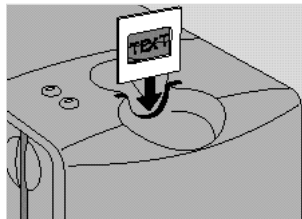

SprintScan 35 LE scanner

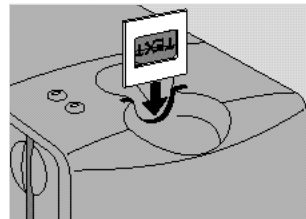

SprintScan 35 ES and Plus scanners

When you choose either the Preview or Scan commands, the SprintScan scanner automatically moves the slide down for scanning and then returns it to the start position when scanning has been completed.

35mm filmstrips
and other materials

To scan an unmounted slide or a 35mm filmstrip negative,

- 1 Open the filmstrip carrier. The carrier is hinged on one edge.
- 2 Place the film into the carrier as shown below. Avoid touching the surface of the film with your fingers.

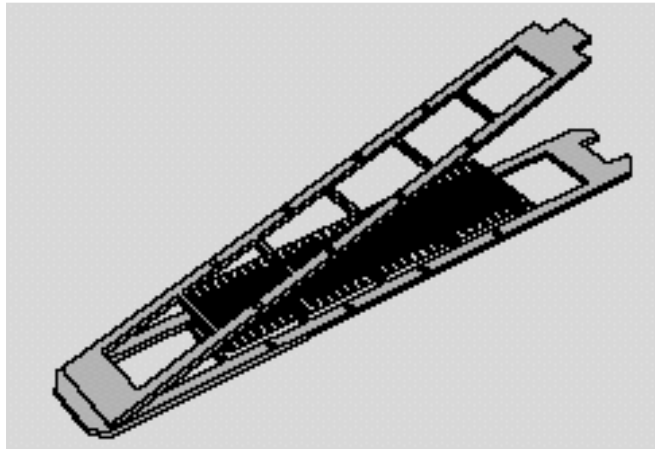

- 3 Remove any slide that may be in the top access slot. You can't insert the filmstrip carrier while a slide is in the scanner.

- 4 Insert the carrier from the right (as you face the scanner) into the side access slot near the top of the scanner, with the emulsion side of the film strip facing the rear of the scanner and the image right side-up for the LE scanner and upside-down for the ES and Plus scanners. See the following figures.

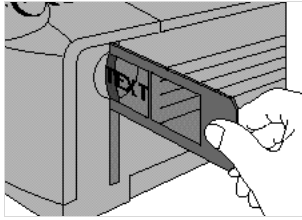

SprintScan 35 LE scanner

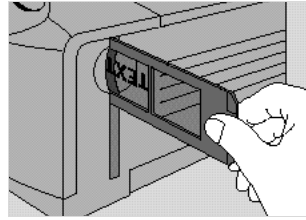

SprintScan 35 ES and Plus scanners

- 5 Slide the filmstrip carrier to the left to line up the image you want to scan. As you slide the carrier, you'll detect a slight click as each frame is positioned for scanning.

Important! The filmstrip carrier moves in one direction – from right to left as you face the front of the unit. If you go past the image you want, you'll have to remove the carrier all the way from the left side and then insert it again from the right.

When you choose either the Preview or Scan commands, scanning proceeds as described for slides.

3 Care and maintenance

Maintenance

The SprintScan 35 scanners require very little maintenance. If the scanner becomes dirty, unplug it, then simply wipe it off with a damp (not wet) cloth with some mild soap or detergent. Do not use harsh cleaners as they could damage the case or mar its appearance.

Warning: Do not use any kind of spray directly on the scanner. The spray could get inside the scanner, damaging the bulb, the lens, or the mechanism.

All the scanners are shipped with a spare lamp. See page 3-2 for lamp replacement.

Fuse replacement

The SprintScan 35 ES has an accessible external fuse that can be replaced (see page 3-4). The SprintScan 35 ES has other, internal fuses, and the LE and Plus have only internal fuses. If you suspect an internal fuse has failed, do not attempt to disassemble the scanner. To do so could result in severe electrical shock and damage to the scanner. This action may also void your warranty. Contact your service representative or Polaroid Technical Support.

Changing the lamp

The scanning lamp should be replaced if it begins to flicker or dim, or if the ready light does not come on. A spare lamp is included inside the scanner's front cover.

Use only a 4-Watt tubular fluorescent lamp with a 5/8-inch diameter. The U.S. lamp specification is F4T5 Cool White (CW), and the European/Asian specification is TL4W/33. Contact your dealer for the proper replacement lamps.

Important: The quality of scans can be affected by dirt or smudges on the lamp. The best assurance of a clean lamp is to wear cotton gloves while changing the lamp and to avoid touching the lamp except at the ends.

Follow these steps to change the lamp:

- 1 Remove the slide or filmstrip from the scanner.
- 2 Turn off the scanner.
- 3 Open the front cover by pressing the release button underneath the front and lifting the cover upward, as shown in the following figure. The cover lifts completely off.

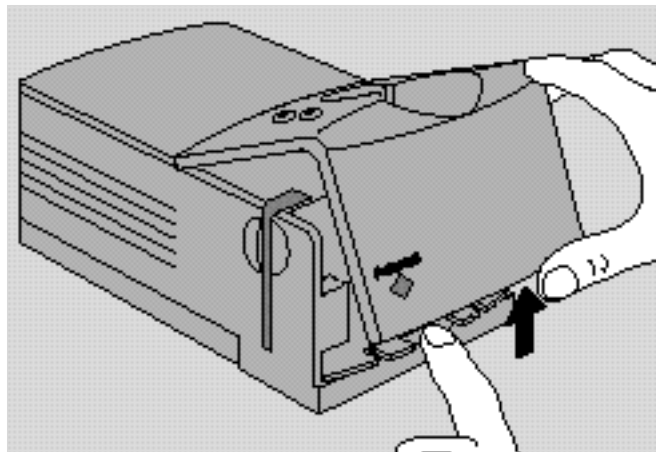

- 4 If the lamp is still hot, wait for it to cool for a few minutes before attempting to remove it.

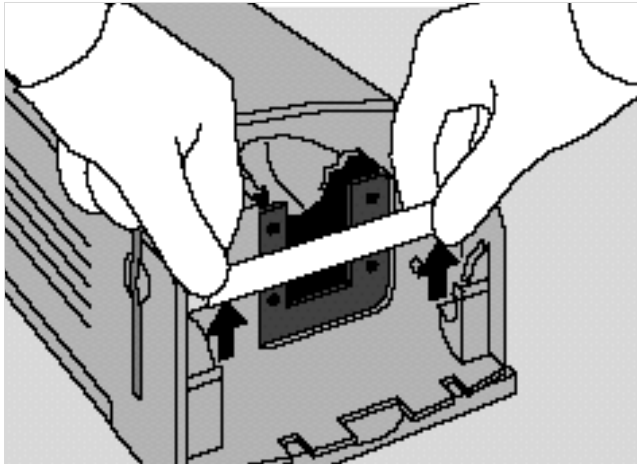

- 5 Grasp the lamp by both ends, near the housing, and pull upward one end at a time to free it from the sockets.

Some resistance is normal.

- 6 Remove the spare lamp from inside the front cover of the scanner. It's held in place with two clips.

- 7 Holding the new lamp by both ends, push each end downward into the sockets.

Some resistance is normal, but avoid excessive force. If an end does not go in fairly easily, you may need to rotate the lamp slightly to line up the connectors.

- 8 Replace the front cover of the scanner.

You may now want to turn on the scanner so that it can run the self-test. Both the power indicator light and the ready light should glow steadily.

Discard the old lamp in an appropriate way, just as you would any used light bulb. Order a new spare from your dealer.

Changing the fuse (ES scanner only)

The fuses in the SprintScan 35 ES scanner are meant to prevent damage to the scanner's circuitry in case of inappropriate power surges or electrical short. Fuses may sometimes simply blow out from old age. If you have a fuse failure, you should always try to find out the cause. Replacing the fuse alone may not solve the problem. Contact your dealer or Polaroid Technical Support whenever you suspect a blown fuse.

Only one fuse is user accessible; this section describes how to check and replace that fuse. However, it is best to have a qualified technician deal with fuse problems.

Warning: The scanner has internal fuses as well as the externally accessible fuse. If you suspect an internal fuse has failed, do not attempt to disassemble the scanner. To do so could result in severe electrical shock and damage to the scanner. This action may also void your warranty. Contact your service representative or Polaroid Technical Support.

Use only a fuse that meets the specifications of the SprintScan 35 ES scanner: 1.6 Amp, 250 Volt.

- 1 Turn off the scanner, and move it so that the back panel is accessible.
- 2 Remove the power cord from the plug so that you can open the fuse receptacle located just below the plug.
- 3 Using a small screwdriver or similar tool, pry the receptacle from the top to remove it from the scanner. See the following figure.

4 Slide the fuse out of the receptacle, as shown.

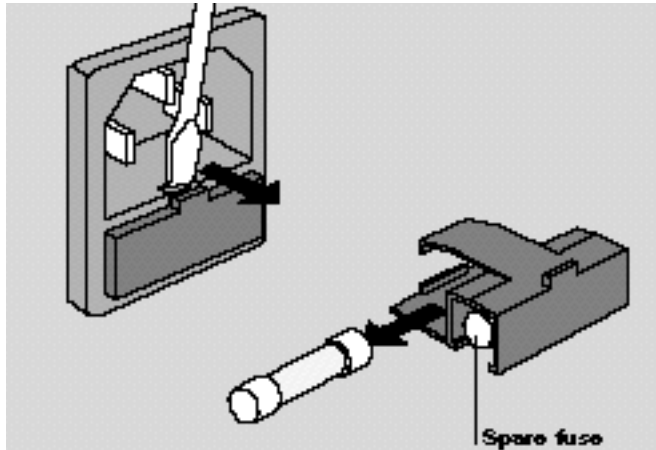

5 Check that the fuse is indeed blown. A blown fuse no longer has a solid metal piece visible inside the glass cylinder.

6 Remove the spare fuse provided with the scanner from the receptacle.

7 Slide the new fuse into the active part of the fuse receptacle.

8 Replace the receptacle in the scanner housing.

9 Reattach the power cord, reposition the scanner, and turn the scanner on to run the self-test.

If the power indicator light does not come on, contact your dealer or Polaroid Technical Support. Replace the spare fuse with a new one as soon as possible.

The Polaroid SprintScan 35 Slide Scanners are designed for trouble-free operation. As with most complex electronic devices and systems, however, problems may occur. This chapter lists some common difficulties and suggests solutions. Causes of problems are suggested in order of seriousness.

If you cannot resolve a software or hardware problem using this chapter, contact Polaroid Technical Support (see page 1-4). Before you call, have ready the following information:

- A description of the problem and the wording of any error messages that you see on your screen when the problem occurs
- The model of your computer (including the kind of processor) and the amount of RAM you have
- The model and serial number of your SprintScan 35
- A list of other devices attached to your system, such as CD-ROM drives, printers, external hard disks, and other SCSI devices
- A list of any other cards and drivers that you are using, including video card and driver
- A list of other applications you are using

Also, we recommend that you run a system diagnostic utility to provide detailed information about your system before you call.

The power indicator light on the scanner does not light up when the scanner is turned on.

Turn off the power and check that the scanner's power cord is plugged in and that the socket it's plugged into is operational. If you are using a power bar, make sure the power bar is plugged in and that it is untripped and working.

If the scanner power indicator still does not light up, even with a confirmed power outlet, then the fuse may need to be replaced. See pages 3-4-3-5 (ES only) or call Technical Support.

The power indicator light comes on, but the ready light does not.

Check that the lamp is firmly seated in the sockets and that it is not burned out.

Try running the software. If the software runs, then the ready light is faulty. If the software does not start, then the scanner's self-test may have detected a problem. Contact your dealer or Polaroid Technical Support.

Nothing happens when you click Preview

It's normal for the scanner to pause before scanning for calibration. After the calibration cycle, the carrier should begin to lower for the preview scan.

The scanner does not return to the start position after scanning.

Turn off your computer. Turn the scanner off, wait a few seconds, and then turn it on again. The mechanism should return to the start position. If it does not, turn the scanner off and carefully remove the front cover to remove the slide. Then contact your dealer or Polaroid Technical Support. Do not attempt to force the mechanism.

The filmstrip carrier will not come out of the scanner. Make sure the cover is completely closed. Gently push the carrier from right to left as you face the front of the scanner. If it still does not come out, do not attempt to force the filmstrip carrier. Contact your dealer or Polaroid Technical Support.

SCSI problems

There is a communication problem between the computer and the scanner.

- Check that the scanner is plugged in and turned on.
- Check the SCSI connections. Are both ends of the cable securely fastened?
- Check that the scanner is properly terminated.
- Does any other SCSI device in the chain, if you have any, use the same SCSI ID number? Each device must have a unique number.
- Check the Read Me file for more information.

SprintScan 35 warranty

Polaroid Corporation warrants the SprintScan 35 against defects in manufacture or workmanship for a period of one year from the date of purchase. To verify the warranty period, you should keep the invoice, sales receipt, or other proof of the purchase date.

Should this product or any component or accessory included with it, except software, prove to be defective at any time during the warranty period, Polaroid Corporation will, at its discretion, either replace or repair this item, without charge. This warranty does not cover damage caused by accident, incorrect installation, unauthorized modification, and misuse of abuse. A charge will be made for repair of such damage.

This warranty excludes all consequential damages and does not affect your statutory rights.

SprintScan 35 service

U.S.A. and Canada

If your SprintScan 35 Scanner requires service, call Polaroid Technical Support toll-free from within the U.S.A. at 1-800-432-5355, Monday through Friday, 8 a.m. to 8 p.m., (Eastern Time). From Canada, call toll-free at 1-800-268-6970.

To return the scanner for service, pack it carefully in its original shipping carton or other sturdy container, with plenty of padding. Shipping instructions will be provided by the Polaroid Technical Support specialist you talk to.

Outside North America

Please contact your nearest Polaroid dealer (see pages 3-9 – 3-10).

Warning: Nothing inside the scanner except for the lamp (and one fuse in the ES scanner) are user serviceable. Do not attempt to disassemble the scanner. To do so could result in severe electrical shock and damage to the scanner. This action may also void your warranty.

Polaroid Offices and Service Centers

Australia
Polaroid Australia Pty Ltd
13-15 Lyonpark Road
PO Box 163
North Ryde, NSW 2113
Tel.: (02) 950 7000
Fax: (02) 887 2209

Belgique/België
Polaroid (Belgium) S.A.-N.V.
rue Colonel Bourg 111
Kolonel Bourgstraat 111
1140 Bruxelles-1140 Brussel
Tel.: +32 2 726 97 00
Fax: +32 2 726 92 99
Toll free line: 32 2 78 155 905

Brasil
Polaroid do Brasil Ltda.
Av. Paulista, 1776/11º andar
Cerqueira Cesar
São Paulo - Capital
01310-921
Tel.: 55.11.285.6411
Fax: 55.11.283.2625
288.6521
287.5393

Canada
Polaroid Canada Inc.
350 Carlingview Drive
Rexdale, ON M9W 5G6
Toll free: 1-800-268-6970

Danmark
Polaroid a.s.
Blokken 75
Postboks 9
3460 Birkerød
Tlf.: 42 81 75 00
Fax: 42 81 70 26

Deutschland
Polaroid GmbH
Spremlinger Landstrasse 109
63069 Offenbach
Tel.: 069 8404 444
069 8404 999

España
Polaroid (España), S.A.
Paseo de la Castellana, 130-7ª Plta.
28046-Madrid
Tno.: 34-1-411.38.36
Fax: 34-1-411.40.73

France
Polaroid (France) S.A.
4, rue J.P. Timbaud, B.P. 47
78391 Bois d'Arcy Cédex
Tel.: (1) 30 85 61 6

Great Britain
Polaroid (U.K.) Ltd.
Ashley Road, St. Albans
Hertfordshire AL1 5PR
Tel.: 0800 010119

Hong Kong
Polaroid (Far East) Ltd.
Wheathampstead House
Codicote Road
Wheathampstead
Hertfordshire AL4 8SF
Freefone: 0800 010119

Italia
Polaroid (Italia) S.p.A.
Via Piave 11
21051 Arcisate (Varese)
Tel.:0332-470031
Fax: 0332-478249

Japan
Nippon Polaroid Kabushiki Kaisha
Mori Building, No. 30
2-2 Toranomon 3-chome
Minato-ku
Tokyo (105)
Tel.: 81-3-3438-8811
Toll free: 0120-248716

México
Polaroid de México S.A. de C.V.
Paseo de la Reforma 195-Piso 14
C.P. 06500 México, D.F.
Tel.: 703-1111
Fax: 566-0505
Del interior al 91 (800) 70-727
Ventas 91 (800) 70-747

Nederland
Polaroid Nederland B.V.
Zonnebaan 45
3606 CH Maarssen
PO Box 1219
3600 BE Maarssen
Tel.: 31-30-410-420
Fax: 31-30-411-969

Reparaties:
Polaroid (Europa) B.V.
Hoge Bothofstraat 45
7511 ZA Enschede

New Zealand
Polaroid New Zealand Ltd.
Camera Services
24-26 Anzac Avenue
Auckland
Tel.: (09) 377 3773

Norge
Polaroid (Norge) A/S
Industriveien 8B
Postboks 80
1471 Skårer
Tlf.: 67 90 47 10
Fax: 67 90 51 73

Österreich
Polaroid Ges.m.b.H.
Eitnergasse 5A
1231 Wien
Tel.: 869 86 27
Fax: 869 81 00

Portugal
Polaroid (Espanña) S.A.
Sucursal em Portugal
Avda. Helen Keller, 19-A
1400 Lisboa
Tel.: (01) 363.85.46

Puerto Rico
Polaroid Caribbean Corporation
Centro de Seguros
Ave. Ponce de León 701,
Miramar, Santurce 00907
Tel.: (809) 725-6240
Fax: (809) 725-5462

Schweiz/Suisse/Svizzera
Polaroid AG
Hardturmstrasse 133
8037 Zürich
Tel.: (01) 277.72.72

Suomi
Polaroid Oy
Sinikalliontie 10
02630 Espoo
Puh: 90-502 35 33
Fax: 90-502 35 50

Sverige
Polaroid AB
Ekholmsvägen 36
Box 204
127 24 Skärholmen
Tel.: 08-710 08 50
Fax: 08-740 73 68

U.S.A.
Polaroid Corporation
Technical Assistance
Toll Free: 1-800-432-5355

Radio and television interference (LE and Plus)

FCC Notice (U.S.A.)

Note: This equipment has been tested and found to comply with the limits for a Class B digital device, pursuant to Part 15 of the FCC Rules. These limits are designed to provide reasonable protection against harmful interference in a residential installation. This equipment generates, uses and can radiate radio frequency energy and, if not installed and used in accordance with the instructions, may cause harmful interference to radio communications. However, there is no guarantee that interference will not occur in a particular installation. If this equipment does cause harmful interference to radio or television reception, which can be determined by turning the equipment off and on, the user is encouraged to try to correct the interference by one or more of the following measures:

- Reorient/relocate the receiving antenna.
- Increase the separation between the equipment and receiver.
- Connect the equipment into an outlet on a circuit different from that to which the receiver is connected.
- Consult the dealer or an experienced radio/TV technician for help.

Note: Shielded interface cable with ferrite core installed on scanner connector end must be used with this equipment.

Caution: Changes or modifications not expressly approved by the manufacturer responsible for compliance could void the user's authority to operate the equipment.

Radio and television interference (ES)

FCC Notice (U.S.A.)

This equipment has been tested and found to comply with the limits for a Class A digital device, pursuant to Part 15 of the FCC Rules. These limits are designed to provide reasonable protection against harmful interference when the equipment is operated in a commercial environment. This equipment generates, uses and can radiate radio frequency energy and, if not installed and used in accordance with the instructions, may cause harmful interference to radio communications. Operation of this equipment in a residential area is likely to cause harmful interference in which case the user will be required to correct the interference at his own expense. Note: Changes or modifications not expressly approved by the party responsible for compliance could void the user's authority to operate this equipment.

EMI Notice (Canada)

This Digital Apparatus does not exceed the Class A limits for Radio Frequency noise from Digital Apparatus set out in the Radio Interference Regulations of the Canadian Department of Communications.

Notice (Europe)

This is a Class A product. In a domestic environment this product may cause radio interference, in which case the user may be required to take adequate measures.

Appendix A: Specifications

Environment	Operating temperature: 50°F to 104°F (10°C to 40°C) Operating relative humidity: 20% to 80% Storage temperature: -20°F to 160°F (-30°C to 70°C) Storage relative humidity: 5% to 90% (noncondensing) Altitude: 0 to 10,000 feet (3,048 meters)
Electrical	Operating voltage: 100-240 VAC, 48-62 Hz Average power consumption, at idle: 30 W @115 VAC, 60Hz Maximum power consumption during scanning: 35 Watts
Light source	4 Watt tubular fluorescent cool white lamp <ul style="list-style-type: none">• U.S. specification: F4T5CW• European/Asian specification: TL4W/33
Size	Dimensions: 5 x 7 x 10 inches (15.2 x 17.8 x 22.5cm) Weight: 5.5 lbs. (2.5 kg)
Feed system	Input system: holder mechanism for mounted slides or carrier. Documents: 35mm slides, mounted in 2 x 2 in. (50mm) mounts, including ANSI-standard plastic mounts. 35mm film strips, unmounted, in lengths of one to six frames (using carrier).

	LE	ES	Plus
Sampling depth	10 bits/color	10 bits/color	12 bits/color
Output	8 bits/color 256 levels/color	8 bits/color 256 levels/color	8 bits/color 256 levels/color
Resolution	72-1950 dpi (optical) 72 - 3900 (interpolated)	127 - 2700 dpi (optical)	127 - 2700 dpi (optical)
Digital interface	SCSI 2: one 50-pin and one 25-pin connector	SCSI 2: two 50-pin connectors	SCSI 2: one 50-pin and one 25-pin connector
Signal processing	Software-based color processing and sharpening	Hardware-based image processing (see below)	Hardware-based image processing (see below)

Hardware-based image processing (ES and Plus)

- Automatic exposure and analog gain and offset calibration
- 2-point digital uniformity correction
- 3-dimensional color correction
- Adaptive sharpening
- Automatic scene analysis and exposure adjustment

Environmental impact The SprintScan 35 Slide Scanners do not use products, parts, or materials manufactured with or containing Class I or Class II Ozone Depleting Substances as listed under the Montreal Protocol.

Index

A

application memory, 1-2
ASPI-compliant SCSI board, 1-3, 2-7

C

cleaning the scanner, 3-1
connecting the scanner, 2-7–2-9
connection warnings, 2-5, 2-7

D

digital interface, A-1
DOS, 1-3

E

environmental impact, A-1
error messages, 1-4

F

filmstrip carrier
 illustration of, 1-5
 jam, 3-7
 slot, 2-1
 use of, 2-12–2-13

front cover

opening, 3-2
release button, 2-1, 3-2

fuse

failure, 3-1
receptacle (ES only), 2-2
replacement (ES only), 3-4

H

help, 1-4

I

IBM PC compatible, 1-3
inserting slides
 mounted, 2-11
 unmounted, 2-12
Internet address, Polaroid, 1-4

L

lamp
 replacement, 3-2–3-3
 spare, 1-5
 specification, A-1

M

Macintosh system software, 1-2
memory, application, 1-2

P

- packing list, 1-5
- PC system, 1-1, 1-3
- Pentium microprocessor, 1-3
- Photoshop plug-in-compliant software, 1-2
- plug-in software, 1-2
- Polaroid Offices and Service Centers, 3-9–3-10
- Polaroid Technical Support, 1-4, 3-6
- positioning the scanner, 2-3–2-4
- power cord, 1-5, 2-10
- power cord socket, 2-2, 2-3
- power indicator light, 2-1, 2-10, 3-6
- Powerbook computer, 1-2, 2-5
- powering up, 2-10
- Preview command, 2-12, 2-13

Q

- quick scanning guide, iii

R

- radio and television interference, 3-11–3-12
- ready light, 2-1, 2-10, 3-7
- registration card, 1-4
- resolution, 1-1, 1-2, A-1

S

- sampling depth, A-1
- Scan command, 2-12, 2-13
- scan size, maximum, 1-2
- scanner
 - cleaning, 3-1
 - connecting, 2-7–2-9
 - description of, 1-1
 - different models of, 1-1
 - for Macintosh users, 1-1
 - for Windows users, 1-1
 - models illustrated, 2-2–2-3
 - parts of, 2-1–2-3
 - software for, 1-1, 1-2

SCSI

- adapter in a PC, 1-3, 2-7
- cable, 1-5, 2-7
- chain information, 2-4–2-5, 2-8
- configurations, illustrated, 2-8–2-9
- connectors, 2-2, 2-3
- problems, 3-7
- termination switch (PLUS only), 2-3, 2-5, 2-7, 2-8
- terminator, illustrated, 1-5. See also termination

SCSI ID numbers

- changing, 2-2, 2-3, 2-6
- selector switch/wheel, 2-6

SCSI-2 cable, 2-5

- service, 3-8

signal processing, A-1

slide

- insertion, 2-11
- orientation, 2-11, 2-13
- slot, 2-1

- spare lamp, 1-5
- specifications, A-1–A-2
- SuperSlides, 1-1
- system diagnostic utility, 1-4, 3-6
- system requirements, 1-2–1-3

T

- technical support, 1-4, 3-6
- termination, 2-4, 2-7
- 35mm slides, 1-1, 2-11
- troubleshooting, 3-6–3-7
- TWAIN driver software, 1-1

U

- unpacking the scanner, 1-5

V

- voltage range of scanner, 1-1, A-1

W

- warranty, 3-8
- Windows operating system, 1-1, 1-3